

4th generation engine power

AGCO SISU POWER
FI-37240 Linnavuori, Nokia
FINLAND

TEL: +358 3 3417 111
 FAX: +358 3 3417 330
 EMAIL: info@AGCOsisupower.com
 WEB: www.AGCOsisupower.com

AGCO SISU POWER is the only engine manufacturer within the AGCO Corporation, and both its head office and main factory are located in Nokia, Southern Finland. In addition to the Nokia facility, AGCO SISU POWER also has factories in Brazil (Sao Paulo), and Russia (Vladimir, about 150 km from Moscow). Whilst AGCO SISU POWER operates on a global basis, ultimate responsibility and control, for both engine design and manufacturing operations, remains with the head office in Nokia, Finland.

Strategy of AGCO SISU POWER

- Profitable growth by extending markets within AGCO and 3rd party business.
- To offer and further develop a comprehensive and a well standardised engine family for off-road use.
- To maintain position as the world's leading supplier of customer-oriented electronic engine control
- To maximise engine efficiency according to customer requirements, whilst minimising carbon footprint
- To offer economical methods for emission control.
- Continuous research for use of alternative fuels

AGCO SISU POWER is continuously studying the needs of off-road engine users in order to further develop its engine family to satisfy the future needs of the industry.

AGCO SISU POWER engine family

AGCO SISU POWER offers the most comprehensive off-road engine family in the 50 to 500hp range, with engine displacement of 3.3 to 9.8 litres. This engine range is designed to use common components, allowing the customer to reduce spare part stocks, as well as easing the logistics burden. The engine family concept also allows easy engine installation for various applications, and helps off-road equipment designers to standardise their own designs, further reducing manufacturing and spare part costs.

Today's engine offering is divided in to 3, 4, 6, and 7 cylinder units, and with this range AGCO SISU POWER is able to offer its customers optimal engine solutions within the 50 to 500 hp power bracket. The detailed specification for AGCO SISU POWER engines can be modified according to customer requirements. This allows for optimal performance and installation, as well as bespoke communication between engine and vehicle electronics.

The basic design of AGCO SISU POWER engines has been optimized for off-road use, where tractors are the main application. For this reason the mechanical construction of AGCO SISU POWER engines is designed to offer a solid solution for frameless body construction, where the oil sump and flywheel housing actually form part of tractor structure. Robust construction of the engine helps to minimise deformations of the body and to reduce noise and vibrations transmitted to the vehicle cabin. With over 65 years of experience, AGCO SISU POWER engines have an excellent reputation for offering customer-oriented design, low fuel consumption, solid performance and pleasant noise levels.

Our reputation for reliability and durability is valued by customers all around the globe.

AGCO SISU POWER's 4th Generation engine family is designed to fulfil the next stage of emission regulations for both the EU and the USA, which apply to engines over 130 kW from the beginning of year 2011 and for engines below 130 kW from the year 2012.

Engines over 56 kW are turbocharged and in most applications, also intercooled and equipped with SCR aftertreatment technology.

This technology helps AGCO SISU POWER to reduce emissions and at the same time, improve engine performance and efficiency, thus maintaining their position as the world's leading supplier of economical off-road engines.

Employing some 700 people, the AGCO SISU POWER factory is a state-of-the-art manufacturing facility and produces some 30,000 units a year. Following the major investment, the entire production process has been completely updated in recent years. The total site extends to 10 hectares including a covered floor area for the production halls of some 3 hectares. Advanced flexible production technology has been designed to manufacture all strategic components in-house. Around one hundred industrial robots with integrated functions together with a highly-skilled workforce are focused on high quality output and optimum productivity.

The core engine is assembled on a fully automated line by robots and further customised and dressed by trained technicians to meet a variety of application requirements. Engines are conveyed via AGVs (automated guided vehicles) from the assembly line to the test area.

In addition to focusing on the development and production of environmentally-friendly engines with excellent fuel economy, the

company is also committed to environmentally friendly production processes. The environmental management system meets ISO 14001 standards and administrative functions are managed according to ISO 9001. Both are certified and regularly audited by Det Norske Veritas (DNV)

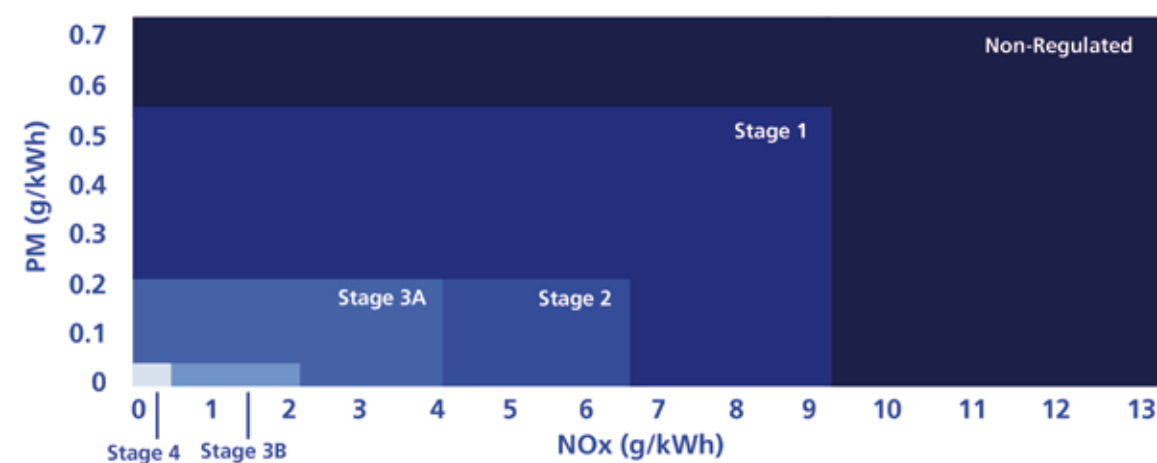

4th Generation series

For the most demanding off-road machinery applications



©2008 AGCO Corporation. All rights reserved. AGCO SISU POWER is a worldwide brand of AGCO.

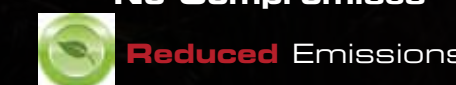

No Compromises

SCR Technology Overview

Engines with SCR (Selective Catalytic Reduction) are designed to deliver all the energy you need – in the form of undiminished horsepower and torque. It also delivers up to 10 percent better fuel economy. Most importantly, the emissions from an engine with SCR are cleaner.

The SCR technology treats the downstream exhaust with AdBlue/DEF, which breaks down into harmless nitrogen and water vapour.

Bottom line, the SCR process, along with SisuTronic engine management, allows AGCO SISU POWER diesel engines to run better, stay cooler and last longer.

The system components

The main components of the SCR system are a tank and an injection system for AdBlue/DEF, as well as an SCR catalytic converter. The SisuTronic diagnostic system monitors the AdBlue/DEF level and indicates when the tank requires refilling.

The Fluid

AdBlue/DEF (Diesel Exhaust Fluid) is a non hazardous, high-purity, colourless solution containing 32.5% urea. The remainder is simply deionised water. Urea is made of ammonia and carbon dioxide. It is used as an artificial fertilizer and it is also found in cosmetics, amongst many other products

The Process

The fluid is sprayed into the exhaust gases as they leave the engine. Within the catalytic converter the

exhaust heat helps transform the urea into ammonia, which then reacts with the nitrogen oxides and converts them into harmless nitrogen gas and water vapour.

With SCR, the nitrogen oxide (NOx) reduction process takes place within the exhaust line - so as to not diminish engine performance.

The process is simple: AdBlue/DEF is sprayed into the hot exhaust gases. The fluid consists of urea and deionized water. This mixture passes through a catalytic converter.

When the hot exhaust combines with the AdBlue/DEF within the catalytic converter, the exhaust gas is broken down into harmless nitrogen and water vapour - two natural components of the air we breathe.

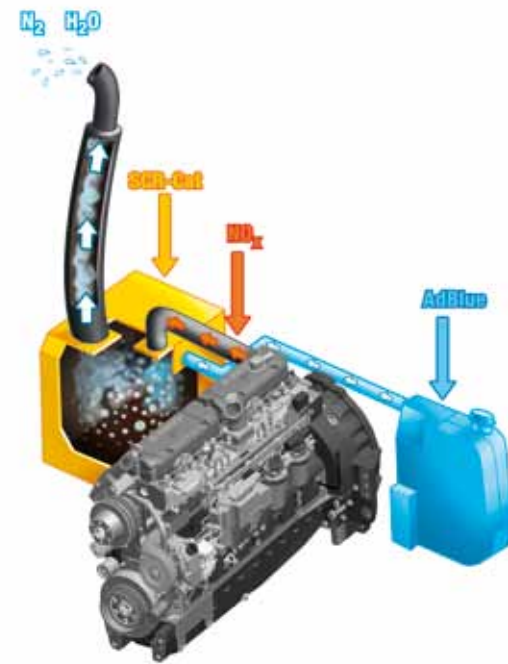

Benefits of the SCR in Stage 3B

- Up to 10 % improvement in fuel economy - Best on the market.
- Offers remarkably lower heat rejection to coolant than other solutions - Significantly lower fan power and noise - Smaller and less expensive cooling package
- Engines utilizing SCR technology are highly tolerant to low quality fuel - High durability in all market areas
- Clean burn technology allows longer oil drain intervals due to very low oil sooting
- Highly efficient combustion minimizes particulate emissions - Particulate filters that require regeneration can thus be avoided.
- Fast load and speed response due to proven bypass turbocharging technology
- SCR is proven technology, already widely used by the truck industry. The infrastructure for AdBlue/DEF availability is already established

Features of Stage 3B engines

- Next Generation Common Rail system with 1800 bar injection pressure
- Best standardization on market - Efficient spare parts logistics and easy installation
- Low friction piston rings minimize friction loss and oil consumption

- Closed Crankcase Ventilation recirculates blow-by gases - No blow-by emission to environment
- Minimized noise emission with optimized combustion
- Excellent quality and durability
- Well tested technology - Extensive lab and field tests

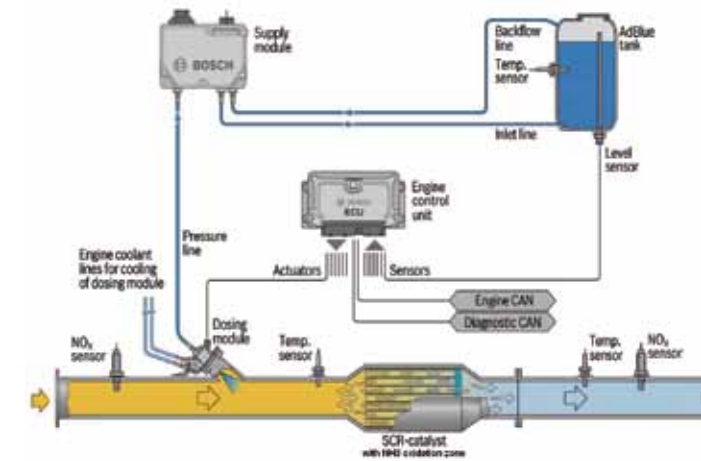

4th generation SisuTronic engine control

AGCO SISU POWER Stage 3B engines feature a new generation of SisuTronic engine control electronics that enhance and extend the proven technology of stage 3A SCR engines. New and further improved features include:

- + **Sequenced injection process** – The whole injection process is completely controlled by the SisuTronic. Injection timing, pressure and sequence are automatically optimized according to operation conditions.
- + **Multi-power and multi-governor performance** – Torque and power curves are selected according to operation mode and conditions to achieve highest performance and efficiency.
- + **Cruise control functions** – For both travel speed and for PTO shaft speed. Maximum speeds can be set via the CAN-bus connection.
- + **Warning systems** – Engine protection warnings are integral to the control system.
- + **Service displays** – Maintenance messages are displayed in order to optimize scheduled service and performance. The serial number and other engine information is also electronically displayed to simplify service.
- + **CAN-bus compatible** – Communication via SAE J1939 CAN-bus simplifies engine upgrades
- + **Fuel monitoring** – Fuel consumption and load are monitored in real-time to optimize power transmission, efficiency and economy.
- + **Shut-down log** – Every engine shut-down is monitored and recorded to facilitate problem solving and service.
- + **Integrated SCR control** - Powerful ECU with leading edge

computing power enables full system control in the same ECU in order to reduce system complexity and cost.

- + **Advanced Control strategies** - Utilizing Model Based Calculations provides precise control for Fuel and AdBlue injection in all operating conditions offering high performance with low emissions.
- + **Flexible control possibilities** - Via CAN-bus, analog and digital interface makes the system suitable to all product categories from basic to high end level.
- + **Customer specific settings** - Enabled with SisuTronic EEM4 software to make the engine compatible with all applications

	EU	USA
1st Generation	Stage 1	Tier I
2nd Generation	Stage 2	Tier II
3rd Generation	Stage 3A	Tier III
4th Generation	Stage 3B	Tier IV Interim
5th Generation	Stage 4	Tier IV Final